



**Sailing Instructions
NORCAL HIGH SCHOOL DOUBLEHANDED
CHAMPIONSHIP**

**Hosted by Tiburon Yacht Club
At Treasure Island Sailing Center
April 1-2, 2006**

1. RULES

- 1.1 The regatta will be governed by the Rules as defined in the 2005-2008 Racing Rules of Sailing, and the ISSA Procedural Rules.
- 1.2 Appendix Q in RRS will apply.
- 1.3 CJ Class rules are changed to delete the requirement for membership of the CFJ Class.

2. NOTICES TO COMPETITORS

Notices to competitors will be posted on the official notice board located at Treasure Island Sailing Center.

3. CHANGES TO SAILING INSTRUCTIONS

Any changes to the sailing instructions will be posted by 0900 on the day it will take effect, except any changes to the schedule of races, which will be posted by 1900 on the day before it will take effect.

4. SIGNALS MADE ASHORE

- 4.1 Signals made ashore will be displayed from the flagpole by the launch ramp at TI.
- 4.2 When flag AP is displayed ashore, the warning signal will be made not less than 5 minutes after removal unless at that time the race is postponed again or abandoned.

5. BOATS

5.1 ISSA Procedural Rules regarding equipment will apply.

5.2 Competitors shall report any damage or loss of equipment, however slight, to the race committee/regatta organizing authority's representative immediately upon completion of the race in which it occurs.

5.3 The penalty for infringement of the above instructions will be disqualification from all races sailed in contravention of these instructions.

6. SCHEDULE OF EVENTS

Saturday, April 1, 2006

0800-0930 Registration & Boat Inspection

0830-0945 Rigging of Boats

1000 Competitors' Meeting

1045 First Warning. Racing will continue throughout the day. Lunch will be available between rotations. There will be no lunch break. NOTE: racing may continue until dusk. Boats remain at TI overnight.

Sunday, April 2, 2006

0800-0900 Rigging of Boats

1000 First Warning. Racing will continue throughout the day. Lunch will be available between rotations. There will be no lunch break.

1600 No race will be started after this time.

1700 Trophy Presentation

All times are approximate. Any foreseeable changes will be posted as soon as possible.

7. RACING AREA/VENUE

7.1 The sailing area will be in the cove at Treasure Island. Rotations will be made on the docks at the Treasure Island Sailing Center.

7.2 Team members, coaches and spectators will be able to watch the racing from TI's docks,

8. COURSES/FORMAT

8.1 Diagrams in Attachment A show the courses, including the approximate angles between legs, the order in which marks are to be passed, and the side on which each mark is to be left. Short college-style courses will be used.

8.2 Windward, leeward, reach, start and finish pins will be inflatable buoys.

8.3 The Race Committee will run as many races as possible, up to a complete Round Robin. Rotations will be done off TI's docks, and sailors will be expected to rotate quickly and efficiently.

9. START

9.1 The starting line will be between a staff displaying a flag on the race committee boat and the starting buoy.

9.2 Races will be started in accordance with ISSA Procedural Rule 7.8 (Sound Signals).

10. RECALLS

10.1 Each yacht's recall number shall be its sail number.

10.2 Individual recalls will be made in accordance with RRS Appendix Q6.

10.3 A General Recall will be signaled by multiple sound signals. In accordance with ISSA Procedural Rules the "Round-the-Ends" provisions of RRS 30.1 shall then apply, without the need for any signal to be given (ISSA PR 7.8 (b)). The three minute starting sequence signal will begin soon after.

11. SHORTENING, ABANDONING OR RESAILING A RACE

In accordance with ISSA Procedural Rule 7.7 (d) races will not be shortened, they will be abandoned in accordance with RRS 32.

12. THE FINISH

The finish line will be between a staff displaying a flag on the Race Committee Finish boat and the finishing buoy.

13. JUDGING/PROTEST

13.1 Judges may be on the water during racing. They will act in accordance with ISSA Procedural Rules, Appendix 4.

13.2 RRS Appendix P (“yellow flag rule”) will be in effect. Before being protested under Appendix P, a warning may be given for a RRS 42 infringement. This does not mean every competitor is entitled to a warning; a flagrant breach of RRS 42 shall not be entitled to a warning. The fleet as a whole shall be entitled to only two warnings in a given day, after which warnings will not be given.

13.3 Protests will be handled in accordance with ISSA Procedural Rules number 16. ISSA Protest forms will be available and must be submitted to the Organizing Authority before the sailor’s next rotation whenever possible, the Protest Committee will hear protests between rotations. Protests will be heard in a designated location determined by the Race Committee.

14. SCORING

Scoring will be as provided in ISSA Procedural Rule 9.

15. COACHING

Team leaders, chaperones, advisors, coaches and other support personnel may not go afloat in the sailing area April 1-2. Coaching will be done from the rotation docks between races. Competitors shall not communicate with a coach before reporting to the Race Committee intent to file a protest. An infringement of this Sailing Instruction shall subject a competitor to disqualification per ISSA Procedural Rules.

16. FOOD

Lunches for Saturday and Sunday will be provided for each registered competitor. Additional lunches for coaches, parents, etc. are available for \$6.00.

17. PARKING

Treasure Island will allow temporary trailer storage in designated areas Friday through Sunday. Ample parking is available around the sailing center. Signs may be posted to indicate both trailer storage and parking areas.

18. PRIZES

18.1 Prizes will be awarded to schools placing 1st, 2nd, and 3rd and to skippers and crews placing 1st, 2nd, and 3rd overall.

19. OFFICIAL NOTICE FOR ALL PCC PARTICIPANTS:

No contestant shall use, either on or off the water, alcoholic beverages (beer, wine, distilled spirits), or use any controlled substance (marijuana, cocaine, etc.), the possession of which is unlawful. Infringements of this regulation and/or other discipline expectations occurring during April 1 & 2, 2006 may be the basis for disciplinary action. Discipline problems and enforcement of this regulation will be handled promptly by an adult Discipline hearing Board which will consist of three adult members; the Regatta Chairman or a designee, a member of the PCISA Board of Directors or a designee and the Chief Judge or a designee. The Discipline Hearing Board shall, at a time and method selected by it, meet to hear any problems and its decision to impose scoring penalties, or any other sanctions it alone deems appropriate, including summary removal from the entire regatta, shall be final without appeal permitted.

Attachment A

Course #1 (Start,W,L,Finish):

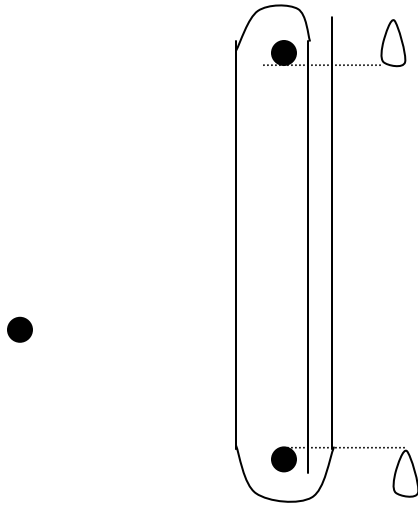

Course #2 (Start,W,R,L,Finish):

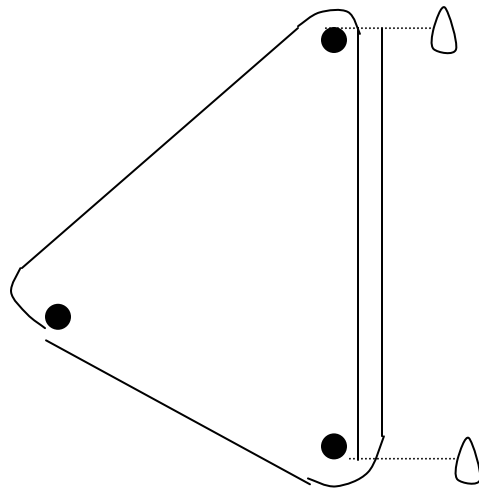

Course #3 (Start,W,L,W,L,Finish):

